

PACKAGE LEAFLET

Package leaflet: Information for the patient

Vastaloma 250 mg oplossing voor injectie in een voorgevulde spuit
fulvestrant

Read all of this leaflet carefully before you start using this medicine because it contains important information for you.

- Keep this leaflet. You may need to read it again.
- If you have any further questions, ask your doctor, pharmacist or nurse.
- This medicine has been prescribed for you only. Do not pass it on to others. It may harm them, even if their signs of illness are the same as yours.
- If you get any side effects, talk to your doctor, pharmacist or nurse. This includes any possible side effects not listed in this leaflet. See section 4.

What is in this leaflet

1. What Vastaloma is and what it is used for
2. What you need to know before you are given Vastaloma
3. How Vastaloma will be given
4. Possible side effects
5. How to store Vastaloma
6. Contents of the pack and other information

1. What Vastaloma is and what it is used for

Vastaloma contains the active substance fulvestrant, which belongs to the group of estrogen blockers. Estrogens, a type of female sex hormones, can in some cases be involved in the growth of breast cancer.

Vastaloma is used either:

- Alone, to treat postmenopausal women with a type of breast cancer called estrogen receptor positive breast cancer that is locally advanced or has spread to other parts of the body (metastatic), or
- In combination with palbociclib to treat women with a type of breast cancer called hormone receptor-positive, human epidermal growth factor receptor 2-negative breast cancer, that is locally advanced or has spread to other parts of the body (metastatic). Women who have not reached menopause will also be treated with a medicine called a luteinizing hormone releasing hormone (LHRH) agonist.

When Vastaloma is given in combination with palbociclib, it is important that you also read the package leaflet for palbociclib. If you have any questions about palbociclib, please ask your doctor.

2. What you need to know before you are given Vastaloma

You should NOT be given Vastaloma

- If you are allergic to fulvestrant or to any of the other ingredients of this medicine (listed in section 6)
- If you are pregnant or breast-feeding
- If you have severe liver problems

Warnings and precautions

Talk to your doctor or pharmacist or nurse before being treated with Vastaloma if any of these apply to you:

- Kidney or liver problems

- Low numbers of platelets (which help blood clotting) or bleeding disorders
- Previous problems with blood clots
- Osteoporosis (loss of bone density)
- Alcoholism.

Children and adolescents

Vastaloma is not for use in children and adolescents under 18 years.

Other medicines and Vastaloma

Tell your doctor or pharmacist if you are taking, have recently taken or might take any other medicines. In particular, you should tell your doctor if you are taking anticoagulants (medicines to prevent blood clots).

Pregnancy and breast-feeding

You must not be given Vastaloma if you are pregnant. Women who are able to become pregnant should use effective contraception while being treated with Vastaloma and for 2 years after your last dose.

You must not breast-feed while on treatment with Vastaloma.

Driving and using machines

Vastaloma is not expected to affect your ability to drive or use machines. However, if you feel tired after treatment do not drive or use machines.

Vastaloma contains 500 mg of alcohol (ethanol) in each injection which is equivalent to 100 mg/ ml (10% w/v). The amount in each injection of this medicine is equivalent to 13 ml beer or 5 ml wine.

The amount of alcohol in this medicine is not likely to have an effect in adults and adolescents.

The alcohol in this medicine may alter the effects of other medicines. Talk to your doctor or pharmacist if you are taking other medicines.

If you are pregnant or breast-feeding, talk to your doctor or pharmacist before taking this medicine.

If you are addicted to alcohol, talk to your doctor or pharmacist before taking this medicine.

Vastaloma contains 500 mg benzyl alcohol per injection, equivalent to 100 mg/ml.

Benzyl alcohol may cause allergic reactions.

Vastaloma contains 750 mg benzyl benzoate per injection, equivalent to 150 mg /ml.

3. How Vastaloma will be given

Your doctor or nurse will give you Vastaloma as a slow intramuscular injection, one into each of your buttocks.

The recommended dose is 500 mg fulvestrant (two 250 mg/5 ml injections) given once a month, with an additional 500 mg dose given 2 weeks after the initial dose.

If you have any further questions on the use of this medicine, ask your doctor, pharmacist or nurse.

4. Possible side effects

Like all medicines, this medicine can cause side effects, although not everybody gets them.

Serious side effects

You may need immediate medical treatment if you experience any of the following side effects

- Allergic (hypersensitivity) reactions, including swelling of the face, lips, tongue and/or throat that may be signs of anaphylactic reactions
- Thromboembolism (increased risk of blood clots)*
- Inflammation of the liver (hepatitis)
- Liver failure

Tell your doctor pharmacist, or nurse if you notice any of the following side effects:

Very common side effects (may affect more than 1 in 10 people)

- Injection site reactions, such as pain and/or inflammation
- Abnormal levels of liver enzymes (in blood tests)*
- Nausea (feeling sick)
- Weakness, tiredness*
- Joint and musculoskeletal pain
- Hot flushes
- Skin rash.
- Allergic (hypersensitivity) reactions, including swelling of the face, lips, tongue and/or throat.

All other side effects:

Common side effects (may affect up to 1 in 10 people)

- Headache
- Vomiting, diarrhoea, or loss of appetite*
- Urinary tract infections
- Back pain*
- Increase of bilirubin (bile pigment produced by the liver)
- Thromboembolism (increased risk of blood clots)*
- Decreased levels of platelets (thrombocytopenia)
- Vaginal bleeding
- Lower back pain irradiating to the leg on one side (sciatica)
- sudden weakness, numbness, tingling, or loss of movement in your leg, especially if only on one side of your body, sudden problems with walking or balance (peripheral neuropathy).

Uncommon side effects (may affect up to 1 in 100 people)

- Thick, whitish vaginal discharge and candidiasis (infection)
- Bruising and bleeding at the site of injection
- Increase of gamma-GT, a liver enzyme seen in a blood test
- Inflammation of the liver (hepatitis)
- Liver failure
- Numbness, tingling and pain
- Anaphylactic reactions.

* Includes side effects for which the exact role of Vastaloma cannot be assessed due to the underlying disease.

Reporting of side effects

If you get any side effects, talk to your doctor, pharmacist or nurse. This includes any possible side effects not listed in this leaflet. You can also report side effects directly via the national reporting system listed in Appendix V. By reporting side effects you can help provide more information on the safety of this medicine.

5. How to store Vastaloma

Keep this medicine out of the sight and reach of children.

Do not use this medicine after the expiry date which is stated on the carton or syringe labels after EXP. The expiry date refers to the last day of that month.

This medicine does not require any special temperature storage conditions.

Store the pre-filled syringe in the original package, in order to protect from light.

Your healthcare professional will be responsible for the correct storage, use and disposal of Vastaloma

This medicine may pose a risk to the aquatic environment. Do not throw away any medicines via wastewater or household waste. Ask your pharmacist how to throw away medicines you no longer use. These measures will help protect the environment

6. Contents of the pack and other information

What Vastaloma contains

- The active substance is fulvestrant. Each pre-filled syringe (5 ml) contains 250 mg fulvestrant.
- The other ingredients (excipients) are ethanol (96 per cent), benzyl alcohol (E1519), benzyl benzoate and castor oil refined.

What Vastaloma looks like and contents of the pack

Vastaloma is a clear, colourless to yellow, viscous solution in a pre-filled syringe, containing 5 ml solution for injection. Two syringes must be administered to receive the 500 mg recommended monthly dose.

Vastaloma has 3 pack presentations, a pack containing 1 glass pre-filled syringe, a pack containing 2 glass pre-filled syringes and a pack containing 6 glass pre-filled syringes. One, two or six safety needles (BD SafetyGlide) for connection to each barrel are also provided.

Not all pack sizes may be marketed.

Marketing Authorisation Holder

Zentiva k.s., U kabelovny 130, 10237 Praha 10 – Dolní Měcholupy, Czech republic

Manufacturer

Laboratorios Farmalán, S.A.
Calle La Vallina, s/n, Edificio 2
Polígono Industrial Navatejera
Villaquilambre, León, 24193, Spain

This medicinal product is authorised in the Member States of the EEA under the following names:

Deze bijsluiter is voor het laatst goedgekeurd in maart 2025

The following information is intended for healthcare professionals only

Vastaloma 500 mg (2 x 250 mg/5 ml solution for injection) should be administered using two pre-filled syringes, see section 3.

Instructions for administration

Warning - Do not autoclave safety needle (BD Safetyglide™ Safety Hypodermic Needle) before use. Hands must remain behind the needle at all times during use and disposal.

For each of the two syringes

- Remove glass syringe barrel from tray and check that it is not damaged.
- Peel open the safety needle (SafetyGlide) outer packaging.
- Parenteral solutions must be inspected visually for particulate matter and discolouration prior to administration.
- Hold the syringe upright on the ribbed part (C). With the other hand, take hold of the cap (A) and carefully twist the plastic rigid tip cap in anticlockwise direction. (see Figure 1):

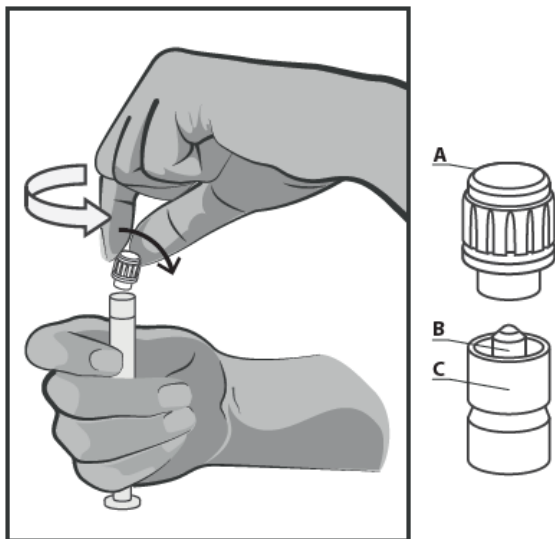

Figure 1

- Remove the plastic rigid tip cap (A) in a straight upward direction. To maintain sterility do not touch the syringe tip (B) (see Figure 2).

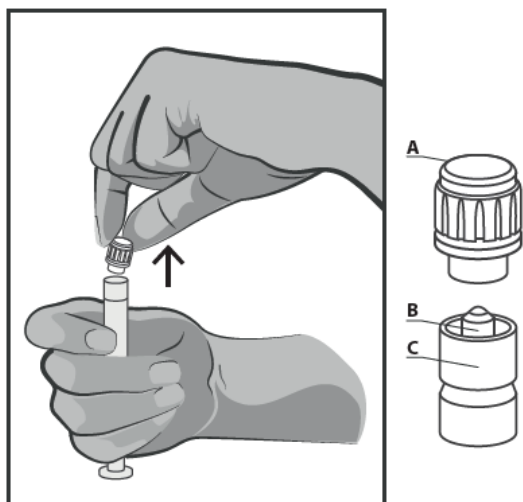

Figure 2

Attach the safety needle to the Luer-Lok and twist until firmly seated (see Figure 3).

- Check that the needle is locked to the Luer connector before moving out of the vertical plane.
- Pull shield straight off needle to avoid damaging needle point.
- Transport filled syringe to point of administration.
- Remove needle sheath.
- Expel excess gas from the syringe.

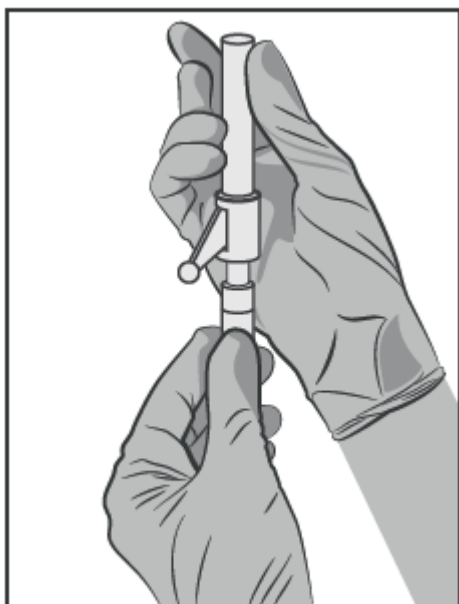

Figure 3

- Administer intramuscularly slowly (1-2 minutes/injection) into the buttock (gluteal area). For user convenience, the needle bevel- up position is oriented to the lever arm (see Figure 4).

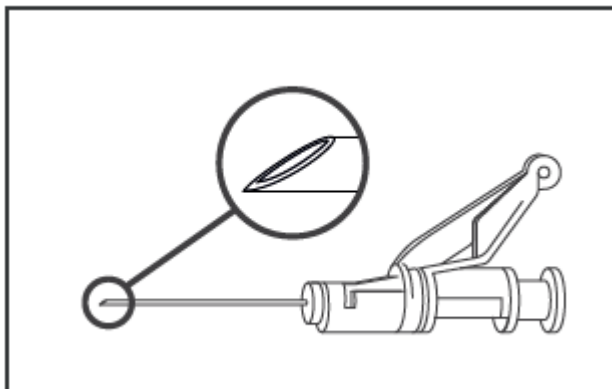

Figure 4

After injection, immediately apply a single-finger stroke to the activation assisted lever arm to activate the shielding mechanism (see Figure 5).

NOTE: Activate away from self and others. Listen for click and visually confirm needle tip is fully covered.

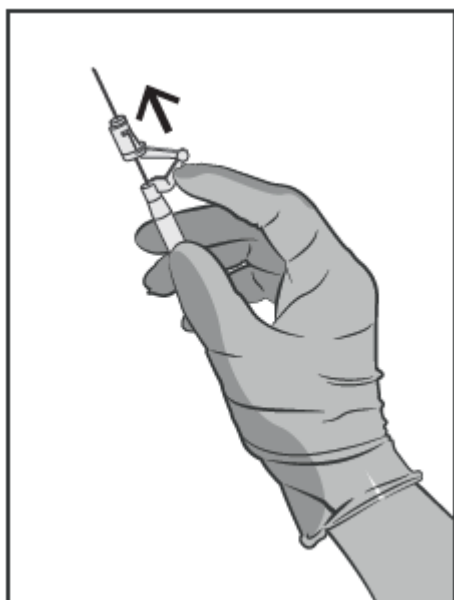

Figure 5

Disposal

Pre-filled syringes are for single use **only**.

This medicine may pose a risk to the aquatic environment. Any unused medicinal product or waste material should be disposed of in accordance with local requirements.